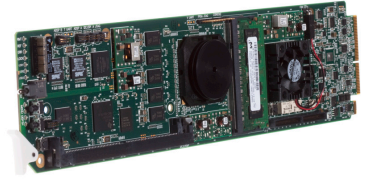
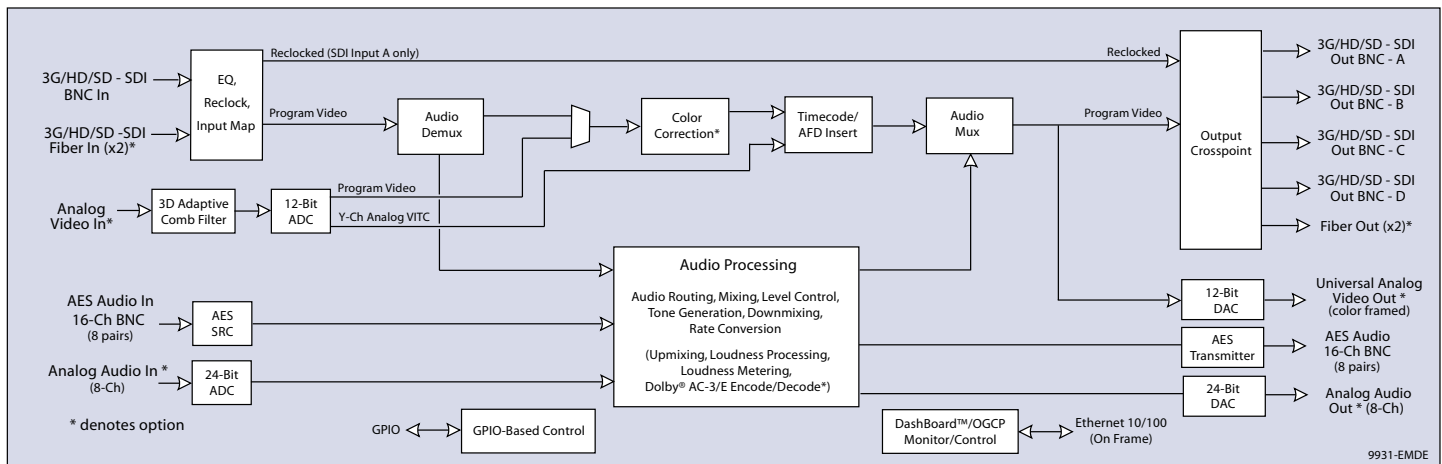

3D Ready

openGear **FUSION^{3G}****9931-EMDE**  LINEAR ACOUSTIC  **DOLBY****3G/HD/SD-SDI Embedder/De-Embedder**

The Fusion3G™ 9931-EMDE is an embedder/de-embedder with 3G/HD/SD-SDI or fiber I/O, as well as analog video, analog audio, and AES audio I/O, all on the same module. This level of integration reduces module count and simplifies the signal chain, as well as providing flexibility for ever-changing system requirements, including 3-D TV compliant 1080p. The 9931-EMDE can be ordered as a base model plus options, allowing tailoring of the product to meet your specific needs. Remote control is quick and easy with the free DashBoard™ remote control software, the Cobalt OGCP-9000 remote control panels, or optional SNMP agent software for openGear™ frames.

In addition to standard highly flexible embed, de-embed, and mixing/routing features, the 9931-EMDE offers advanced options such as Dolby® E/AC-3 encoding and decoding, ITU BS.1770 loudness metering, and Linear Acoustic upmixing and loudness processing. Where the full capability is not required, the 9931 card is available as the following base model versions. If desired later, any of these versions can be field-upgraded to 9931-EMDE functionality using a firmware upgrade, without removing the card from its frame.

Alternate Base Models:**9931-EM** 3G/HD/SD-SDI Embedder**9931-DE** 3G/HD/SD-SDI De-Embedder**9931-EMDE Block Diagram****Features**

- Full 3G/HD/SD-SDI support on fiber* or coax
- Linear Acoustic loudness processing and automatic upmixing technology*
- Complete set of Dolby® E/AC-3 encoding and decoding options
- Fiber ports use blind mating interface, allowing card swapping (including optical transceivers) with no cable disconnection*
- AES ports are soft switchable between input and output. Each input has independent sample rate converter.
- Relay bypass available from SDI input to SDI output*
- Advanced audio processing allows routing, gain, delay, and flexible mixing as standard features
- GPIO ports with user-definable functions and an advanced data logging feature provide the utmost in system automation and monitoring
- Frame sync with reference failover using dual reference inputs on frame
- Composite video input sources converted with 3D comb decoder, mitigating common decoding artifacts
- Composite video output is color-framed to match reference burst, plus user offsetframed to match reference burst, plus user offset
- Centralized GUI remote control using DashBoard™ software and Cobalt OGCP-9000 series remote control panels — presets allow saving and recalling of custom settings
- Five year warranty

* Denotes Option

I/O Options

- **+FRx / +Tx / +RxTx / +RxRx / +TxTx (Fiber Inputs/Outputs)***

Provides one or two fiber connections per card. Inputs can serve any function in the product, outputs can be assigned from any function in the card. Connector type is dual LC with blind-mate connectors cards fully swappable.

- **+ANV (Universal Analog Video Inputs/Outputs)***

Provides an analog video input and output (CVBS, component, RGB (sync on green))

- **+ANA (Analog Audio Inputs/Outputs)***

Provides up to eight channels (total) of balanced analog audio inputs and outputs

*Requires expansion Rear Module (for example, 9931-DFS+ANV requires RM20-9931-XB expansion Rear Module)

Video Options

- **+COLOR (Color Correction)**

Provides independent RGB channel controls for luma, black, and gamma. Ultra-fast response time. The color correction feature is perfectly suited for use with Cobalt OGCP-9000/CC Remote Control Panel.

Audio Options

- **+LP51 / +2LP20 / +LP20 (Linear Acoustic Software Loudness Processing)**

Featuring Linear Acoustic AEROMAX™ technology and available in 5.1-channel (LP51), dual stereo (2LP20), and/or single stereo (LP20), these loudness processors use inputs from any source received by the card, or any mixing setting produced by the card. AEROMAX™ algorithms use a sophisticated multi-band approach to loudness processing, and can apply multi-faceted loudness correction specifically targeted to various frequency ranges and other characteristics within the program material, resulting in audio free from abrupt loudness or image shifts while preserving more of the original content than previously possible.

- **+LM (Software Loudness Meter)**

Cobalt's audio loudness metering option (in conjunction with a Cobalt OGCP-9000 Remote Control Panel) provides a flexible solution for ingest or on-air loudness metering and assessment in compliance with ATSC A/85 and ITU BS.1770. With LKFS measurement, true peak level detection, error tracking and logging, and intuitive interface with touch screen control, this feature provides easy to use and thorough audio level and LKFS assessment information.

- **+UM (Linear Acoustic Software Upmixer)**

Featuring Linear Acoustic UPMAX™ technology, upmixing allows legacy stereo program content to be converted to full 5.1-channel audio. UPMAX™ mode detects 2.0 content and automatically applies upmix mode (with configurable switchover fade-in/fade-out) depending on absence or presence of 5.1 source audio.

- **+DEC (Dolby® E/AC-3 Decoding)**

Decodes AC-3 and Dolby® E signals from AES or embedded sources. Full metadata support; both SMPTE 2020 and serial.

- **+ENCD (AC-3 (Dolby® Digital) Encoding)**

Provides AC-3 encoding from any combination of audio sources supported by the card (including mixed and loudness controlled signals). Full metadata support using internally generated or external metadata via SMPTE 2020 or serial. Metadata can be embedded and/or outputted on a serial port.

- **+ENCE (Dolby® E Encoding)**

Provides Dolby® E encoding from any combination of audio sources supported by the card (including mixed and loudness controlled signals). Full metadata support using internally generated or external metadata via SMPTE 2020 or serial. Metadata can be embedded and/or outputted on a serial port.

Rear Module Options

RM20-9931-B	8321 Frame Rear I/O Module (Double Slot) 1 3G/HD/SD-SDI Input, 4 AES I/O BNCs, 4 3G/HD/SD-SDI Outputs
RM20-9931-C	8321 Frame Rear I/O Module (Double Slot) 1 3G/HD/SD-SDI Input, 8 AES I/O BNCs, 1 3G/HD/SD-SDI Output
RM20-9931-D	8321 Frame Rear I/O Module (Double Slot) 1 3G/HD/SD-SDI Input, 4 AES I/O BNCs, 2 GPIO, 2 3G/HD/SD-SDI Outputs
RM20-9931-E	8321 Frame Rear I/O Module (Single Slot) 1 3G/HD/SD-SDI Input, 8 AES I/O BNCs, 2 GPIO, 4 3G/HD/SD-SDI Outputs
RM20-9931-XB	8321 Frame Rear I/O Module (Double Slot) Component In, 4 Analog Audio I/O, Component Out
RM20-9931-XC	8321 Frame Rear I/O Module (Double Slot) 2 Fiber I/O, 8 Analog Audio I/O (Not available for 8310 openGear™ Frame)

Rear modules also available for 8310 10-slot openGear™ frame (RM-XXXX-X), except where noted.

9931-EMDE

Base Rear Modules shown below represent commonly used I/O configurations. Other I/O combinations are available, as well as custom configurations. Please contact Cobalt sales with inquiries.

Rear Module Options

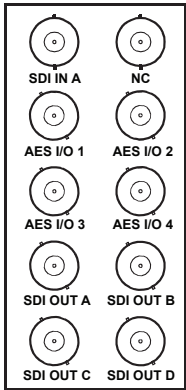

RM20-9931-B

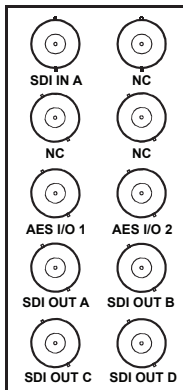

RM20-9931-C

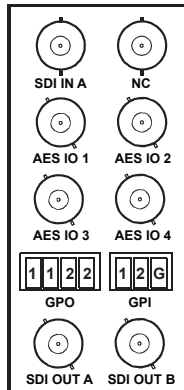

RM20-9931-D

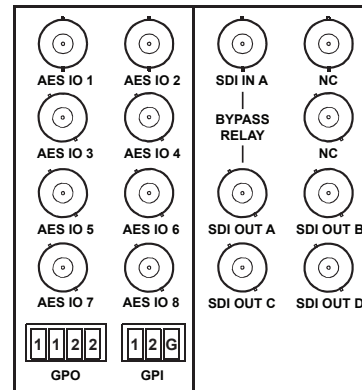

RM20-9931-E

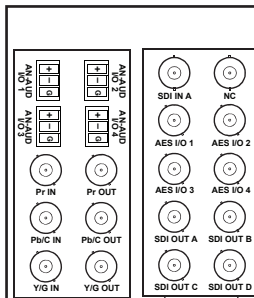

RM20-9931-XB RM20-9931-B

The expansion Rear Modules (modules ending in -XB, etc.) shown here can be installed adjacent to a base module to expand I/O capabilities.

In this example, the I/O capabilities of the RM20-9931-B Rear Module (SDI IN, 4 AES IN or OUT, 4 SDI OUT) are expanded with the RM20-9931-XB to also include 4 analog audio IN and component analog video IN and OUT.

Card must be ordered with appropriate option(s) supporting expansion I/O interfaces (for example, the analog video and audio I/O interfaces shown on expansion RM20-9931-XB require card with +ANV and +ANA).

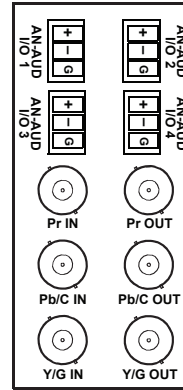

RM20-9931-XB

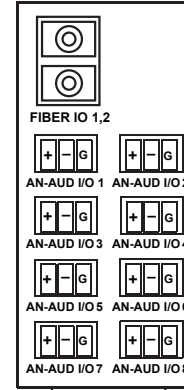

RM20-9931-XC

Specifications

Video Input/Output (1 In, 4 Out)

Standard: SD: 486i59.94, 576i50
 HD: 1080i59.94, 1080i50, 1080p24, 1080p23.98, 1080psf24, 1080psf23.98
 720p59.94, 720p50, 720p24, 720p23.98
 3G: SMPTE 425 level A and B: 1080p59.94, 1080p50
 Cable Length: 3G/HD/SD: 120/180/320 m (Belden 1694A)
 Return Loss: >15 dB up to 1.485 GHz
 >10 dB up to 2.970 GHz
 Alignment Jitter: 3G/HD/SD: < 0.3/0.2/0.2 UI
 Timing Jitter: 3G/HD/SD: < 2.0/1.0/0.2 UI

Frame Reference Input

Signal: SMPTE 170M/318M "Black Burst"
 SMPTE 274M/296M "Tri-Level"
 Return Loss: >35 dB up to 5.75 MHz

Audio/Video Delay

Conversion Latency: 1 frame
 Frame Sync Min Latency: 2 lines
 Video Delay: 3G/HD/SD: 0.5/1.0/5.0 sec
 Audio Delay: 16 channels, per channel adjustment, 1 sample step size
 Up to 5 sec delay for each ch

AES Audio Input/Output (8)

Physical Interface: BNC per AES3-Id
 Input Level: 0.2 to 2 Vp-p
 Output Level: 1.0 Vp-p
 Impedance: 75 Ω
 Return Loss: >15 dB up to 6.144 MHz
 Input SRC Range: 32 to 96 kHz
 Input SRC Performance: >130 dB THD+N

Analog Audio Input/Output

Input Impedance: >10 kΩ
 Input Clip Level: +24 dBu (eq. 0 dBFS)
 Max Output Level: +24 dBu (eq. 0 dBFS)
 Freq. Response: ±0.12 dB (20 Hz to 20 kHz)
 SNR: 115 dB (A weighted)
 THD+N: -96 dB (20 Hz to 10 kHz)
 Crosstalk: -106 dB (20 Hz to 20 kHz)

Analog Video In

ADC bit depth: 12-bit
 Sampling: 54 MHz (4X over-sampling)
 Freq. Response: Y/CVBS : ± 0.25 dB to 30 MHz
 Pb/Pr: ± 0.25 dB to 15.0 MHz
 Noise: < -60 dB to 30 MHz (unweighted)
 Differential Phase: < 1.5 degree
 Differential Gain: < 1 %

Analog Video Out

DAC bit depth: 12-bit
 Freq. Response: Y/CVBS : ± 0.25 dB to 30 MHz
 Pb/Pr: ± 0.25 dB to 15.0MHz
 Noise: < -60 dB to 30 MHz (unweighted)
 Differential Phase: < 1.5 degree
 Differential Gain: < 1 %

Fiber Input/Output

Connectors: Dual LC, Standard Polish
 Fiber Type: 9/125 micron, single mode
 Mating system: Blind mate
 TX power: -5 dBm @ 1310 nm
 RX power: -16 to -3 dBm / 1260 to 1620 nm

GPI (2)

Connector: 3 terminal contact closure
 Mapping: Flexible, input select, ARcing, preset recall, and others

GPO (2)

Connector: 4 terminal, isolated relay contacts
 Mapping: Flexible, error indication, status change, and others

Serial Ports

Connector: Phoenix 3 terminal
 Levels: Software switchable between RS-232 and RS-422/485 specification
 Protocol: Dolby® metadata, logging output, and others

Linear Acoustic, the "LA" symbol, UPMAX, AutoMAX, and AutoMAX-II are trademarks of Linear Acoustic Inc.