

2KW TV VHF SOLID STATE TRANSMITTER

MOD. STV 32

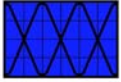



GENERAL DESCRIPTION

The **STV-32** is a solid state MOS-FET 2KW transmitter for TV broadcasting with combined amplification process in the VHF band III, from 170 to 230 MHz .The equipment is fully compliant with the personnel safety requirements as specified in IEC 215 .The rack frame design is very suitable for an easy maintenance and service: each unit can be easily removed and checked.

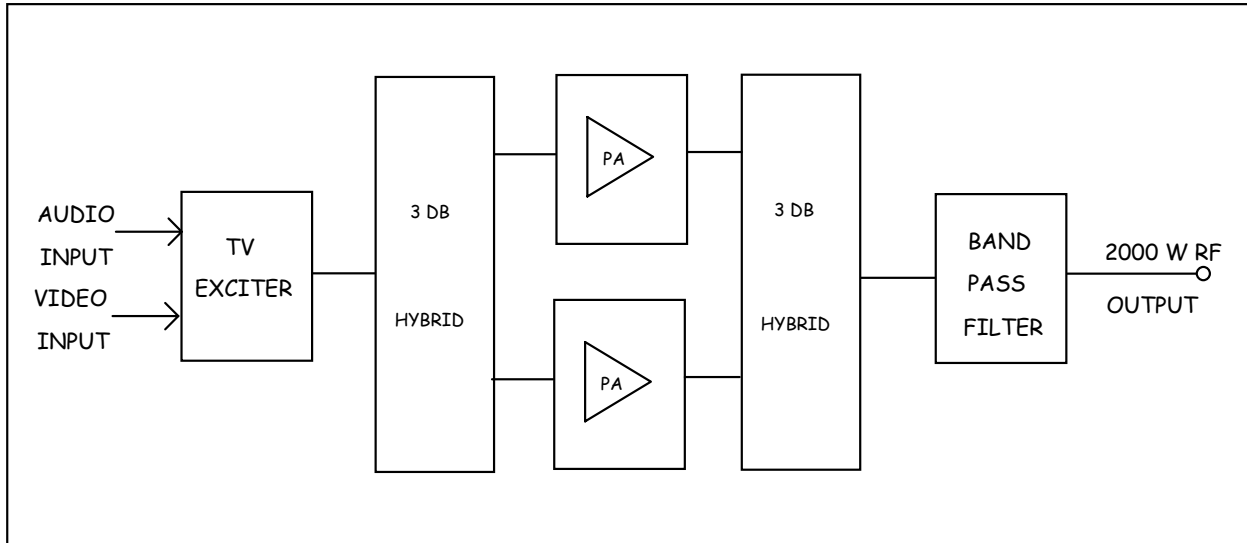

STV 32 - Simplified Block Diagram

EXCITER

The **EXCITER** stage is very flexible due to his modular plug-in design, enable combined and split amplification process as well as adaptation to the various TV standards. All routine on-air adjustment are made by commands from the front panel.

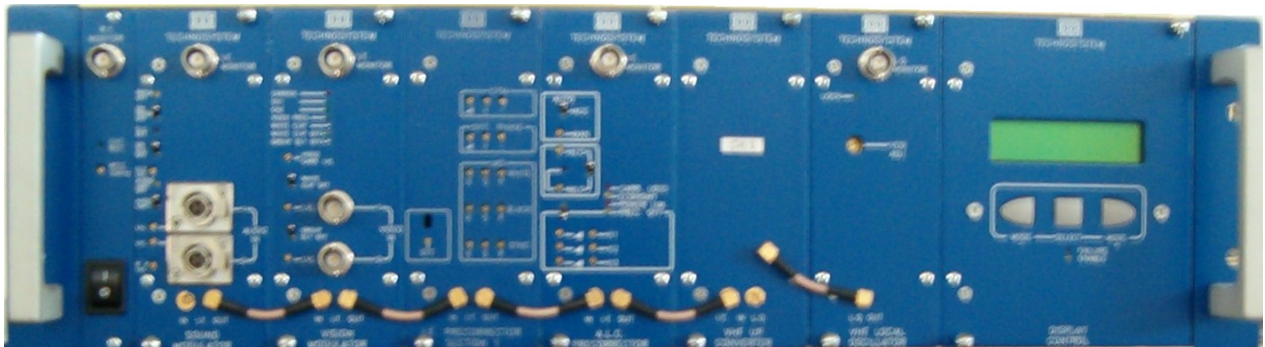

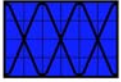

POWER AMPLIFIER

The amplification is made up by 2 RF PAs (power amplifiers, SAV - 31), the nominal output power is 2 KW p.s. The PA employs solid state MOS-FET technology in order to obtain wide band , reliability , and high efficiency . The PA has a built-in switch-mode power supply unit self-protected against overcurrent and overvoltage , as well the overtemperature , overdrive and VSWR for RF parameters.

The basic element of the power amplifiers comprises a mainframe of 4 units rack. The power amplifier employs solid state MOSFET technology, 4 RF pallets and a driver, in order to obtain wide band, reliability, and high efficiency. The ventilation is assured by means of two high efficiency and high MTBF ventilators; the power supply of the final RF modules has been developed by means of switching power supplies directed by the network, one for each RF module, to obtain maximum redundancy, while pilot RF is powered by the same power supplies in parallel (OR). This solution allows for “soft degradation”, that is the reduction of output power in case of malfunctioning of wither an RF module or of a power supply. The heat sync has been designed to obtain very high efficiency levels that allow the amplifiers to function in the most severe of weather conditions.



COOLING SYSTEM

Each amplifier is air cooled with forced ventilation performed by two built-in high reliability blowers. A careful and proper design has been adopted in order to guarantee all the power devices to work safely even in very high temperature environments.

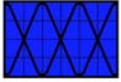

RF

- Frequency range.....	170 to 230 MHz
- Output power.....	2000 W peak sync
- Vision/Sound power ratio.....	10/1 single sound or 20/1/0.2 dual sound
- Output-stage technology.....	solid state MOS-FET
- Vision-Sound amplification.....	combined
- Standards.....	all standards
- Modulation class.....	C3F, F3E
- Sound transmission.....	FM single-sound (IRT or NICAM 728)
- Harmonic and spurious emission....	≤ 1 mW
- IMD products in band	≤ 60 dB
- Frequency stability.....	± 100 Hz / 1 month ± 1 Hz / month
- External reference frequency.....	5 MHz, 0.2 \div 1.0 V / 50 Ω
- Offset capability.....	10/25 Hz steps up to ± 25 kHz

TRANSMISSION CHARACTERISTICS

- Sideband spectrum response.....	according to the standard
- Amplitude-frequency response.....	according to the standard
- Group delay variation	$\leq \pm 35$ ns (without receiver precorrection and sound trap in TV demod.)
- Non linearity distortion..... (mod. 10 to 75%)	$\leq 5\%$
- Differential gain..... (mod. 10 to 75%)	$\leq 5\%$
- Differential phase..... (mod. 10 to 75%)	$\leq \pm 2$ degrees
- Incidental carrier phase..... modulation	± 3 degrees
- Signal to hum (peak value) ratio..... (f < 10 kHz)	≥ -48 dB
- Signal to random noise..... (unweighted 0.2 to 5 MHz)	≥ -56 dB
- Blanking level variation.....	$\leq 2\%$
- 2T k factor.....	$\leq 2\%$
- ICPM (picture range).....	≤ 2 degrees
- Intercarrier S/N ratio.....	≥ 46 dB (referred to ± 50 kHz deviation)

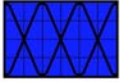

VISION

- Video input..... 2 with aut. Switchover (BNC conn. 75 Ω)
- Colour systems..... PAL / SECAM / NTSC
- Nominal input level..... 1 Vpp \pm 6dB into 75 Ω
- Return loss..... \geq 34 dB
- DC restoration..... clamped to the blanking level without affecting the burst
- White limiter..... at 90% picture signal without affecting the chrominance

SOUND

- Sound input..... 2 with autom. Switchover (video master)
- Nominal input level..... +6 dBm \pm 6dB (\pm 50kHz dev.)
- Input impedance..... 600 Ω balanced
- Pre-emphasis..... 50 μ s (75 μ s on request)

METERING

- peak sync output power
- Reflected power
- Power supply status
- Temperature

PROTECTION CIRCUITS

- VSWR
- Air cooling loss
- Overtemperature
- Overcurrent

REMOTE CONTROL

- Parallel interface..... start, stop, alarm, interlock
- Serial interface..... RS 232

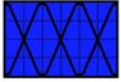

GENERAL

- Mains voltage.....	115/230/400 V AC ±15% single or three phase <i>Others mains voltage available on request</i>
- Mains frequency.....	47/63 Hz
- Temperature range.....	0 to +50°C
- Relative humidity.....	95% not condensing
- Altitude.....	up to 2.500 meters <i>Higher altitude levels are possible on request</i>
- Power consumption (50% APL).....	3500 W
- Power factor.....	≥ 0.9 (TYPICAL ≥ 0.95)
- Ambient dissipation.....	< 300 W
- Air cooling.....	1200 m³/h
Dimensions:	
- Width.....	600 mm
- Height.....	1300 mm
- Depth.....	800 mm
Weight:	185 Kg.

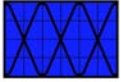

STANDARD INSTALLATION REQUIREMENTS

TRANSMITTER ROOM

The building floor must be suitable to support a capacity :

$\geq 300 \text{ kg / m}^2$

INSTALLATION AREA

It must be clean and free of dust , the transmitter must be installed to have space around enough for ventilation and for maintenance actions to be allowed.

The minimum requirement space for transmitter must be :

2 x 2 x 2 (H) meter

TEMPERATURE

Room temperature does not exceed :

0 to + 50 °C

ELECTRICAL PLANT

The main power installed must be :

$\geq 8 \text{ kVA}$

MAIN VOLTAGE

The three-phase AC voltage must be :

Nominal value + 10 to -15 %

MAIN POWER CABLE SIZE (mm²)

Operation voltage	Phase wires	Neutral wire	Protection earth wire
230 V	≥ 12	not used	≥ 16

AIR COOLING

The room must be capable of :

1200 m³ / h air flow

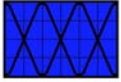

Single Drive

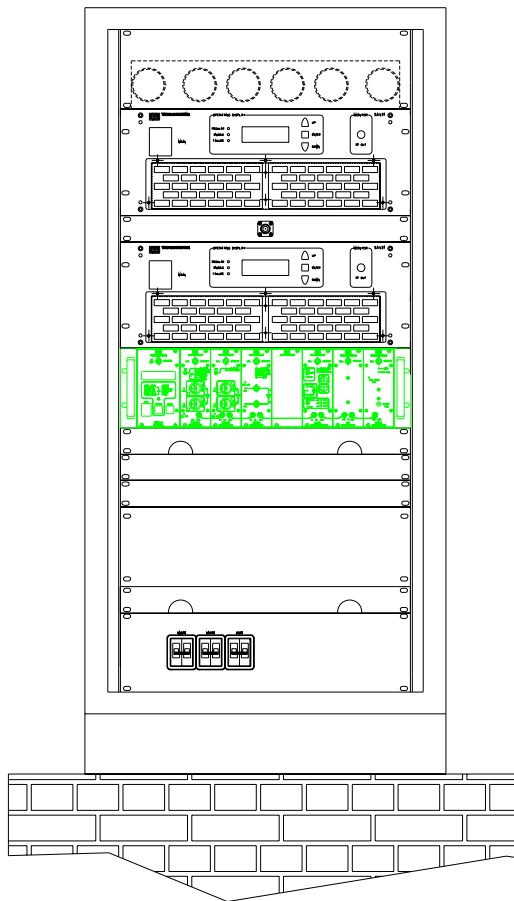

Dual Drive

