

## ADX-2100 / MRX-2100

### CONTROL DATA TRANSLATOR INSTRUCTION MANUAL

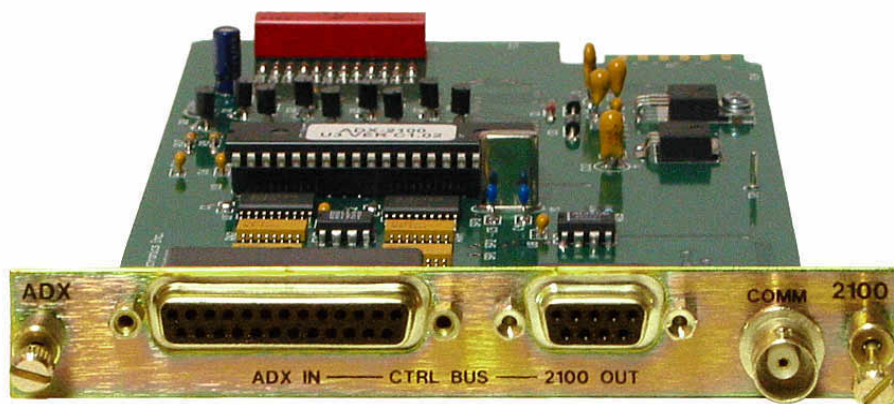

SIGMA ELECTRONICS, INC.  
P.O. Box 448  
1027 COMMERCIAL AVENUE  
EAST PETERSBURG, PA 17520-0448  
(717) 569-2681

# ADX-2100/MRX-2100 CONTROL DATA TRANSLATOR

## GENERAL:

**IMPORTANT NOTE: Remove any SCI present in the Series 2100 system to eliminate the possibility of conflicting data being put on the control data bus. Additionally, the SCI in the ADX or MRX system must be set to Alphanumeric mode (ADX and MRX - S3,1 – OFF) .**

The ADX-2100 and MRX-2100 are modules that translate higher-level control data from Sigma Series ADX and Sigma Series MRX systems for use in Sigma SERIES 2100 & HPX switching systems. The ADX-2100 and MRX-2100 are used in place of the standard SCI-2144 System Control Interface that normally generates the control data in SERIES 2100 switching systems.

Control data is generated in the master frame by the SCI-ADX or SCI-MRX Serial Control Interface module. The interconnect cable transfers the data to the input connector on the ADX-2100 or the MRX-2100 installed in the slaved SERIES 2100 frame. This module translates the data into standard SERIES 2100 format and puts it on the control bus in the slaved frame(s) for use by all modules in the system.

Additionally the ADX-2100 and MRX-2100 connect to the COMM line. The COMM line carries switching instructions from control panels and feeds back status information from slaved units to the master SCI.

## POWER:

The ADX-2100 and MRX-2100 operate from bus voltage of unregulated +20 VDC. This voltage supply is supplied by the Sigma frame / power supply to the ADX-2100 or MRX-2100. The module has two regulators U5 (+12 VDC) and U6 (+5 VDC).

## FRAMES:

The ADX-2100 and MRX-2100 module can reside in any of five different frames provided by Sigma Electronics, Inc. If this module is purchased as a component of a system, please refer to the SERIES 2100 FRAMES Instruction Manual. If the module was purchased separately, an existing frame must be present for proper operation. Sigma would like to emphasize the fact that any of the Series 2100 modules can be installed with any other Series 2100 module within any of the 2100 Series frames. The ADX-2100 and the MRX-2100 are only necessary to allow the medium and larger Sigma switching systems to control the smaller format Sigma switching systems.

- ◆ The SSB-21 frame can be used to house the ADX-2100 or MRX-2100. This will be necessary when all slots in other Series 2100 frames are filled or when slaving a standalone DVM-1616 to an ADX or MRX system.

- ◆ The SS-2100-2 frame is designed for desktop applications. This frame provides two (2) slots for dual module configurations. The only switching system that could be configured in the SS-2100-2 frame would be a Micro Series 4X4 audio or video only system.

The SS-2100-6 frame is designed for 19-inch EIA rack installations. It provides six (6) slots for modules in a 1RU space. A variety of 4X4 and 8X8 systems could be configured in the SS-2100-6 frame.

The SS-2100-12+ frame provides a redundant power supply in a 3RU frame for 19-inch EIA rack applications. This frame has thirteen (13) slot positions for modules.

The SS-2100-16+ frame is also available for installations in a 19-inch EIA rack. This 3RU frame provides seventeen (17) slots for modules.

Additional information on the various frames is available. Please refer to the special section on frames if this was purchased as a complete system. If this information is not provided with this shipment, contact Sigma Electronics for assistance.

## CONNECTIONS:

Control data is transferred to the ADX-2100 or MRX-2100 modules via the connectors located on the rear panel. The ADX-2100 and MRX-2100 have two D-subminiature connectors on the rear panel. One is marked "IN" and the other is marked "OUT". The cable to transfer the control data signals from the Series ADX or MRX Switching system is provided with the ADX-2100 or MRX-2100. This cable connects the ADX "CONTROL BUS OUT" or MRX "OUT" connector to the "IN" connector on the rear panel of the ADX-2100 or MRX-2100.

# ADX-2100/MRX-2100 CONTROL DATA TRANSLATOR

The ADX-2100 or MRX-2100 translates the control data received and supplies it to both the Series 2100 Router motherboard via the internal cardedge connection and the rear Panel "OUT" connector. This connector is used with a Sigma SERIES 2100 system in a multiple frame configuration. The cable for this connection is normally provided with the SLV-2126 or SLC-2102 module in this type of system. Custom cables for unique applications may be obtained from Sigma Electronics, Inc. by contacting technical support at the address/phone number below.

The BNC on the rear panel of the ADX-2100 and MRX-2100 is connected to a coaxial Comm line that carries the switching requests from the remote panels. This Comm line also carries the status information from the ADX-2100 or MRX 2100 back to the SCI in the master frame indicating whether the switch was carried out as requested. This coaxial path should NOT be terminated in a 75Ω load.

## SWITCH SETTING

The DIP switch settings on the ADX-2100 and MRX-2100 must match the parameters of the system in which it is installed. The following chart and table explain the functions of each switch..

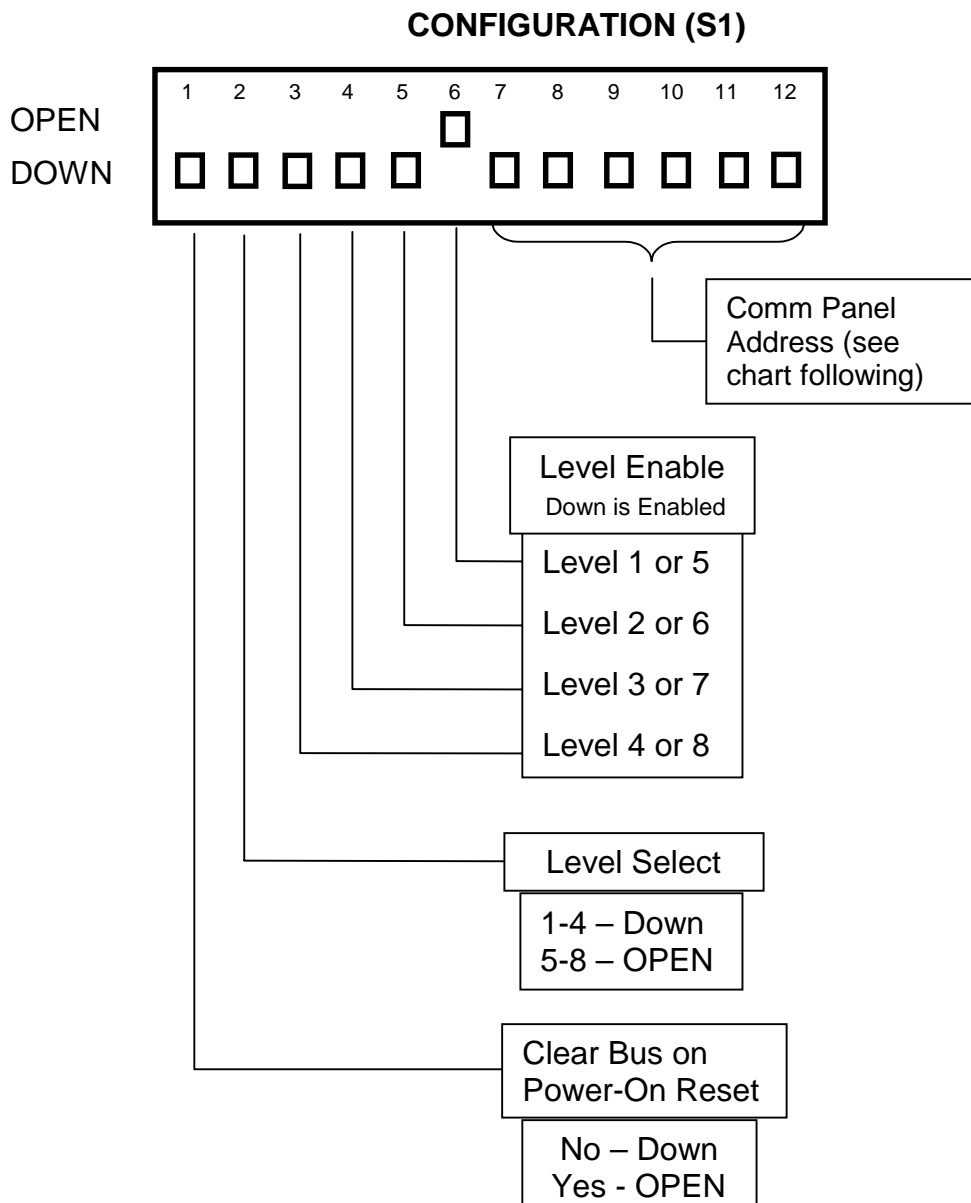

# ADX-2100/MRX-2100 CONTROL DATA TRANSLATOR

## COMM PANEL ADDRESS SWITCH SETTINGS

ADDRESS	S1,7	S1,8	S1,9	S1,10	S1,11	S1,12
1	ON	OFF	OFF	OFF	OFF	OFF
2	OFF	ON	OFF	OFF	OFF	OFF
3	ON	ON	OFF	OFF	OFF	OFF
4	OFF	OFF	ON	OFF	OFF	OFF
5	ON	OFF	ON	OFF	OFF	OFF
6	OFF	ON	ON	OFF	OFF	OFF
7	ON	ON	ON	OFF	OFF	OFF
8	OFF	OFF	OFF	ON	OFF	OFF
9	ON	OFF	OFF	ON	OFF	OFF
10	OFF	ON	OFF	ON	OFF	OFF
11	ON	ON	OFF	ON	OFF	OFF
12	OFF	OFF	ON	ON	OFF	OFF
13	ON	OFF	ON	ON	OFF	OFF
14	OFF	ON	ON	ON	OFF	OFF
15	ON	ON	ON	ON	OFF	OFF
16	OFF	OFF	OFF	OFF	ON	OFF
17	ON	OFF	OFF	OFF	ON	OFF
18	OFF	ON	OFF	OFF	ON	OFF
19	ON	ON	OFF	OFF	ON	OFF
20	OFF	OFF	ON	OFF	ON	OFF
21	ON	OFF	ON	OFF	ON	OFF
22	OFF	ON	ON	OFF	ON	OFF
23	ON	ON	ON	OFF	ON	OFF
24	OFF	OFF	OFF	ON	ON	OFF
25	ON	OFF	OFF	ON	ON	OFF
26	OFF	ON	OFF	ON	ON	OFF
27	ON	ON	OFF	ON	ON	OFF
28	OFF	OFF	ON	ON	ON	OFF
29	ON	OFF	ON	ON	ON	OFF
30	OFF	ON	ON	ON	ON	OFF
31	ON	ON	ON	ON	ON	OFF
32	OFF	OFF	OFF	OFF	OFF	ON
33	ON	OFF	OFF	OFF	OFF	ON
34	OFF	ON	OFF	OFF	OFF	ON
35	ON	ON	OFF	OFF	OFF	ON
36	OFF	OFF	ON	OFF	OFF	ON
37	ON	OFF	ON	OFF	OFF	ON
38	OFF	ON	ON	OFF	OFF	ON
39	ON	ON	ON	OFF	OFF	ON
40	OFF	OFF	OFF	ON	OFF	ON
41	ON	OFF	OFF	ON	OFF	ON
42	OFF	ON	OFF	ON	OFF	ON
43	ON	ON	OFF	ON	OFF	ON
44	OFF	OFF	ON	ON	OFF	ON
45	ON	OFF	ON	ON	OFF	ON
46	OFF	ON	ON	ON	OFF	ON
47	ON	ON	ON	ON	OFF	ON
48	OFF	OFF	OFF	OFF	ON	ON
49	ON	OFF	OFF	OFF	ON	ON
50	OFF	ON	OFF	OFF	ON	ON
51	ON	ON	OFF	OFF	ON	ON
52	OFF	OFF	ON	OFF	ON	ON
53	ON	OFF	ON	OFF	ON	ON
54	OFF	ON	ON	OFF	ON	ON
55	ON	ON	ON	OFF	ON	ON
56	OFF	OFF	OFF	ON	ON	ON
57	ON	OFF	OFF	ON	ON	ON
58	OFF	ON	OFF	ON	ON	ON
59	ON	ON	OFF	ON	ON	ON
60	OFF	OFF	ON	ON	ON	ON
61	ON	OFF	ON	ON	ON	ON
62	OFF	ON	ON	ON	ON	ON
63	ON	ON	ON	ON	ON	ON
64	OFF	OFF	OFF	OFF	OFF	OFF

# ADX-2100/MRX-2100 CONTROL DATA TRANSLATOR

## NOTES:

All specifications, drawings, dimensions, weights and other details are subject to change without notification. Information is intended to give a general performance and operation guideline of the product.

Sigma Electronics, Inc.; P.O. Box 448; 1027 Commercial Avenue; East Petersburg, PA 17520-0448  
Main Office: Tel: (717) 569-2681 Fax: (717) 569-4056  
REV3 NOV02

ADX-2100/MRX-2100