



C O N S O L E S

PRODUCTION Series

"P/S TWO"

Model: PS-2

**Functional, Rack-Bay segmented components made for control room and broadcast environments with multi-users. TYPICAL APPLICATIONS: Production rooms, Broadcast Centers, Master control rooms, Edit Consoles and Monitor Walls**

- base cabinet with 9 ru per bay (adjustable shelves are a no cost option)
- removable front vented access panels;
- front and rear rack rails; open back;
- upper rack turret with 4 ru @ 20 degrees;
- rear monitor ledge for 1 x 20" monitor;
- countertop (18"--28" d), steel support arms in choice of laminate or linoleum finish
- padded holster or solid hardwood edge

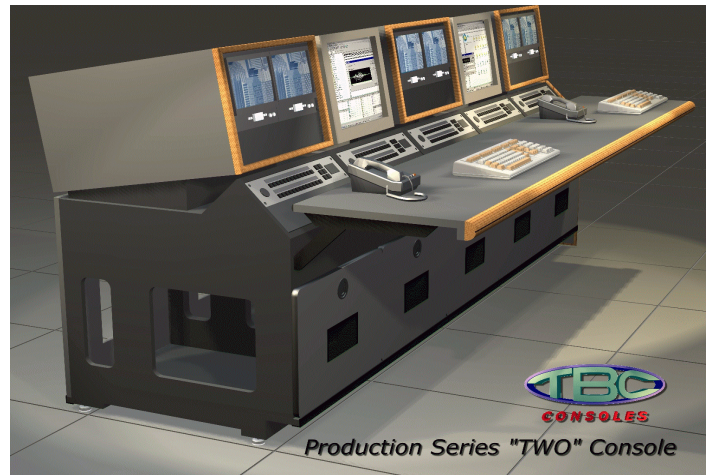

Production Series "TWO" Console

(shown with **optional**, upper rack storage modules)

per rack bay: **\$1,300**  
(shipping + handling additional)

(weight: 225 lbs/bay.)

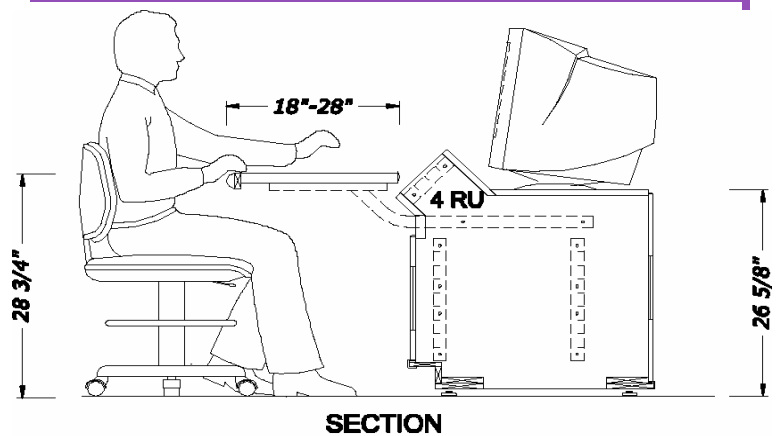
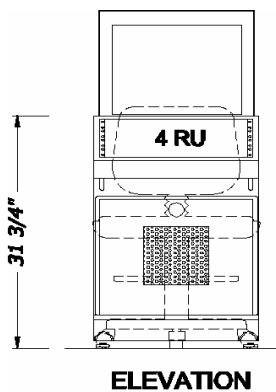
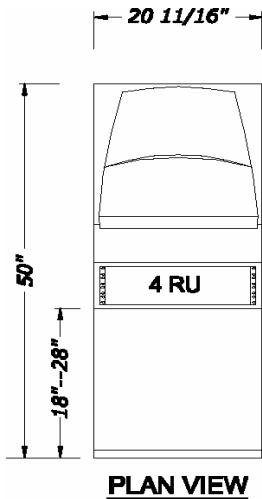

**Optional Finishes per bay**

multi-ply wood edge with laminate top	\$ 120
multi-ply edge with real wood veneer top	235
solid MDF (1.125" thick) with clear lacquer	225
sanded Plexi-glas (1" thick)	435
solid wood (maple, oak, cherry, mahogany)	425
Corian, Fountainhead, Avonite solid surface	690

**Optional Accessories**

monitor riser with ribbed rubber surface	\$ 225
upper rack storage module with 12 ru	335
oak, cherry or mahogany end panel	680
rear vented, removable access doors	145
slide-out keyboard/mousepad platform	435
countertop cutout with component wedge	375

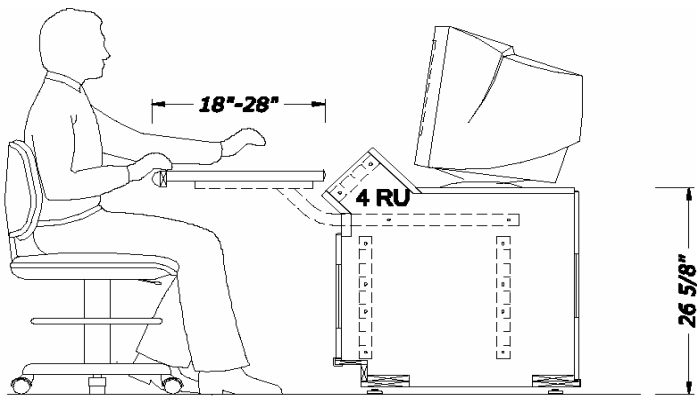

**SECTION**