

World Leader • In-Rack • Audio & Video Monitoring

WOHLER AMP1A-VTR2

Compact, High Quality, 8 Channel Analog Self-Powered Speaker System (2 Groups of 4)

January 16, 2004

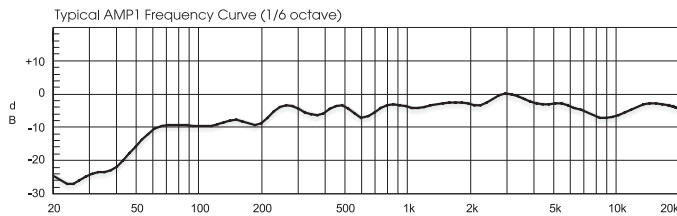

Features:

- Full Fidelity Audio Monitoring in only 1U of rack space
- 8 Balanced Analog Inputs (2 Groups of 4)
- Independent Selection of 2 from 4 Mono Sources to Left and Right Outputs
- Balanced Analog Output of 2 Selected Sources
- Powerful 98dB SPL at 2 feet (0.6m)
- Four 26 Segment Tri-Color Level Meters Displaying Simultaneous VU & PPM
- Premium Quality Drivers & Power Amplifiers
- Extended Frequency Response and Low Distortion
- Focused Sound, Reduces Adjacent Bay Crosstalk
- Audible Indication of Phase/Polarity Problems
- Innovative LED Display of Phase/Polarity Relationships
- Thorough Magnetic Shielding for Placement next to Video Monitors
- Headphone Jack, Mutes Speakers
- Blowout Proof Speakers
- Quick and Simple Installation

The AMP1A-VTR2 provides self-powered, full-fidelity stereo audio monitoring in the smallest rack space possible. Offering 8 eight analog inputs (two groups of 4) this unit has front panel controls allowing the operator to easily select either group of four, and then one of four analog channels to the left and one of the same four to the right for aural monitoring & balanced analog output of the selected channel pair. The AMP1A-VTR2 features four 26 segment LED level meters showing simultaneous VU & PPM for accurate level-metering of all four input sources from the selected input group. This unit contains four high performance transducers driven by three power amplifiers: one amplifier/driver combination handles midrange and high frequency information in stereo, while the second handles summed low frequency information below the 500 Hz crossover point.

The unique design provides optimally focused sound for operators in an Ultra Near Field (1 to 3 ft.) working environment and offers performance comparable to that of many separate monitor pairs, yet does so without the installation hassles, awkward speaker placements and "added-on" look. This provides for a higher SPL for the operator while reducing overall ambient sound and adjacent bay crosstalk.

Extended HF response reveals potential problems with audio whine or hiss and electronic rather than acoustic cancellation of bass frequencies provides positive audible detection of out-of-phase (reversed polarity) audio feeds. A headphone jack is provided on the front panel, usage automatically mutes the speakers. The front panel features an innovative LED Display of Phase/Polarity Relationships. Output limiter circuits are incorporated to protect the speakers, and extensive magnetic shielding allows placement immediately adjacent to video monitors with no color impurities.

The AMP1A-VTR2 is ideally suited for use in VTR bays, mobile production vehicles, teleconferencing installations, multimedia systems, satellite link and cable TV facilities, and on-air radio studios. Built and rigorously tested in the USA, the AMP1A-VTR2 is backed by a strong warranty and a "Satisfaction Guaranteed" return policy.



Audio Monitoring

Level Metering

Alarm Systems

Video Monitoring

Toll Free (US): 1-888-5-WOHLER Tel: (650) 589-5676 Fax: (650) 589-1355 • 713 Grandview Drive, South San Francisco, California 94080, USA

www.wohler.com sales@wohler.com

WOHLER AMP1A-VTR2

Compact, High Quality, 8 Channel Analog Self-Powered Speaker System (2 Groups of 4)

Rear Panel:

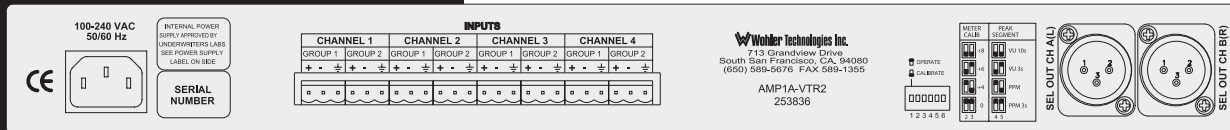

System Diagram:

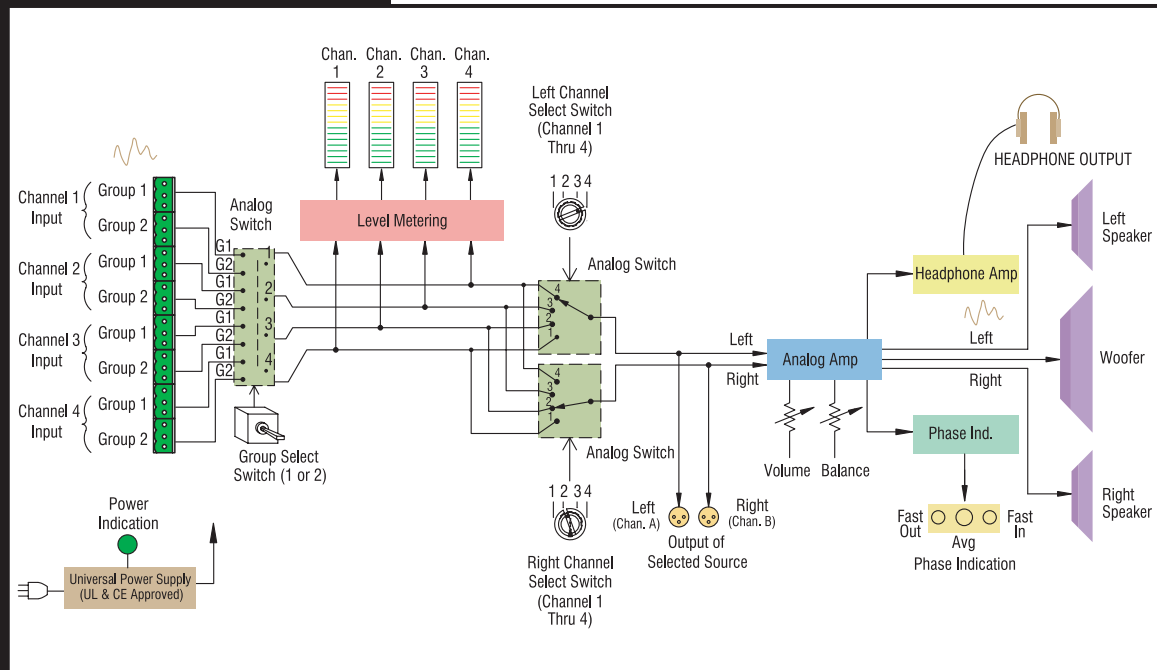

Specifications:

| | |
|---------------------------------|---|
| Input | .8 balanced analog inputs - phoenix terminals |
| Output | .balanced analog output of 2 selected channels - XLR |
| Level meters | .4 x 26 segment bargraphs |
| Level meter scale | .+12 to -50 dB |
| Level meter threshold | -.0, +4, +6, +8 dBv: DIP switch selectable |
| Level meter dynamics | .Simultaneous VU & PPM |
| Midscale resolution | .2 dB |
| Analog input impedance | .>40 kOhms balanced |
| Peak acoustic output @ 2 feet | .98dB SPL |
| Frequency response (1/6 octave) | .80Hz - 20kHz (±5dB) (-10dB @ 50Hz, 22kHz) |
| Power output | .RMS each side (2 Ohms) - 5W, 7W peak RMS dual WOOFER (4 Ohms) - 11W, 16W peak |
| Electrical distortion | .<0.15% at any level below limit threshold |
| Acoustic distortion | .8% or less worst case frequencies above 180Hz including cabinet resonance, typically <2% |
| Hum and noise | .better than -68dB below full output |
| Magnetic shielding | .<0.5 gauss any adjacent surface |
| Power consumption (AVG. MAX.) | .30W |
| Dimensions (HxWxD) | .1.75 x 19 x 12" (44.5 x 483 x 305mm) |
| Weight (approx.) | .9lbs (4kg) |
| Power supply | .100 to 240VAC, 50/60Hz universal input CE and UL approved |

All specifications are subject to improvement



Toll Free (US): 1-888-5-WOHLER Tel: (650) 589-5676 Fax: (650) 589-1355
713 Grandview Drive, South San Francisco, California 94080, USA
www.wohler.com sales@wohler.com