

World Leader • In-Rack • Audio & Video Monitoring

WOHLER AMP2-DA/AVU

Premium Quality, 2 Channel Analog & AES/EBU Self-Powered Speaker System with True VU Meters

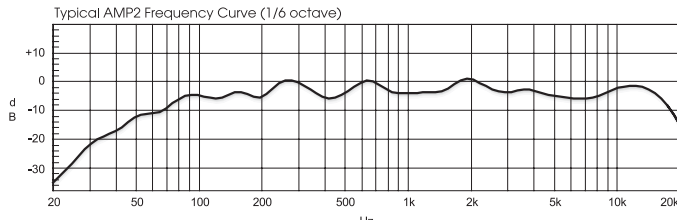

Features:

- Premium Quality Drivers for Superior Reproduction
- 2 Unbalanced AES/EBU Digital Inputs (Select 1)
- 2 Balanced Analog Inputs (1 Stereo)
- Balanced Analog Output of Selected Digital Source
- Powerful 104dB SPL at 2 feet (0.6m)
- 2 Premium Quality Mechanical VU Meters
- Exceeds ANSI VU Meter Specifications
- Extended Frequency Response and Low Distortion
- Focused Sound, Reduces Adjacent Bay Crosstalk
- Audible Indication of Phase/Polarity Problems
- Innovative LED Display of Phase/Polarity Relationships
- Thorough Magnetic Shielding for Placement next to Video Monitors
- Compact & Convenient, all this Power in only 2U of rack space
- Headphone Jack, Mutes Speakers
- Blowout Proof Speakers
- Quick and Simple Installation

The AMP2-DA/AVU is a complete exceptional high quality stereo audio monitoring system for monitoring 2 channels from Analog and AES/EBU Digital sources in a compact two rackspace cabinet. This unit contains three audiophile-quality drivers and three power amplifiers; two speakers and amplifiers reproduce midrange and high frequency information in stereo, while the third amp/driver combination handles summed LF information below the 500 Hz crossover point.

The AMP2-DA/AVU features two Premium Mechanical VU Meters showing VU for superior level-metering. The front panel features an innovative LED Display of Phase/Polarity Relationships. Output limiter circuits are incorporated to protect the speakers, and extensive magnetic shielding allows placement immediately adjacent to video monitors with no color impurities.

The unique design provides optimally focused sound for operators in an Ultra Near Field (1 to 3 ft.) working environment and offers performance comparable to that of many separate monitor pairs, yet does so without the installation hassles, awkward speaker placements and "added-on" look. This provides for a higher SPL for the operator while reducing overall ambient sound and adjacent bay crosstalk. Extended HF response reveals potential problems with audio whine or hiss and electronic rather than acoustic cancellation of bass frequencies provides positive audible detection of out-of-phase (reversed polarity) audio feeds. A headphone jack is provided on the front panel, usage automatically mutes the speakers.

The AMP2-DA/AVU is ideally suited for use in VTR bays, mobile production vehicles, teleconferencing installations, multimedia systems, satellite link and cable TV facilities, and on-air radio studios. Built and rigorously tested in the USA, the AMP2-DA/AVU is backed by a strong warranty and a "Satisfaction Guaranteed" return policy.

October 12, 2004



Audio Monitoring

Level Metering

Alarm Systems

Video Monitoring

Toll Free (US): 1.888.5.WOHLER • Tel: 510.870.0810 • Fax: 510.870.0811 • 31055 Huntwood Avenue, Hayward, California 94544, USA

www.wohler.com sales@wohler.com

WOHLER AMP2-DA/AVU

Premium Quality, 2 Channel Analog & AES/EBU Self-Powered Speaker System with True VU Meters

Rear Panel:

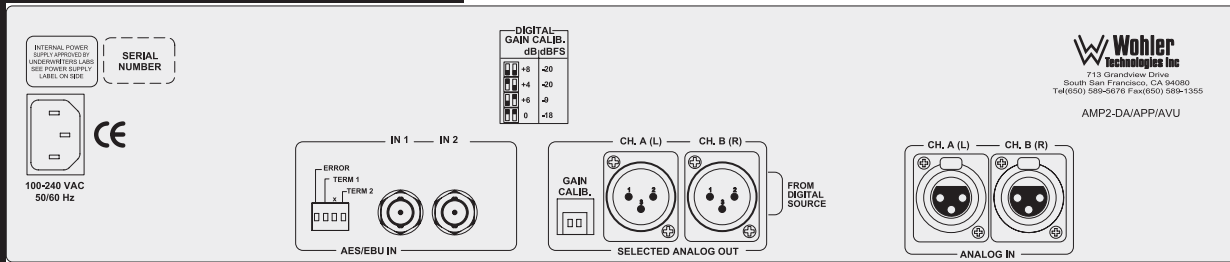

System Diagram:

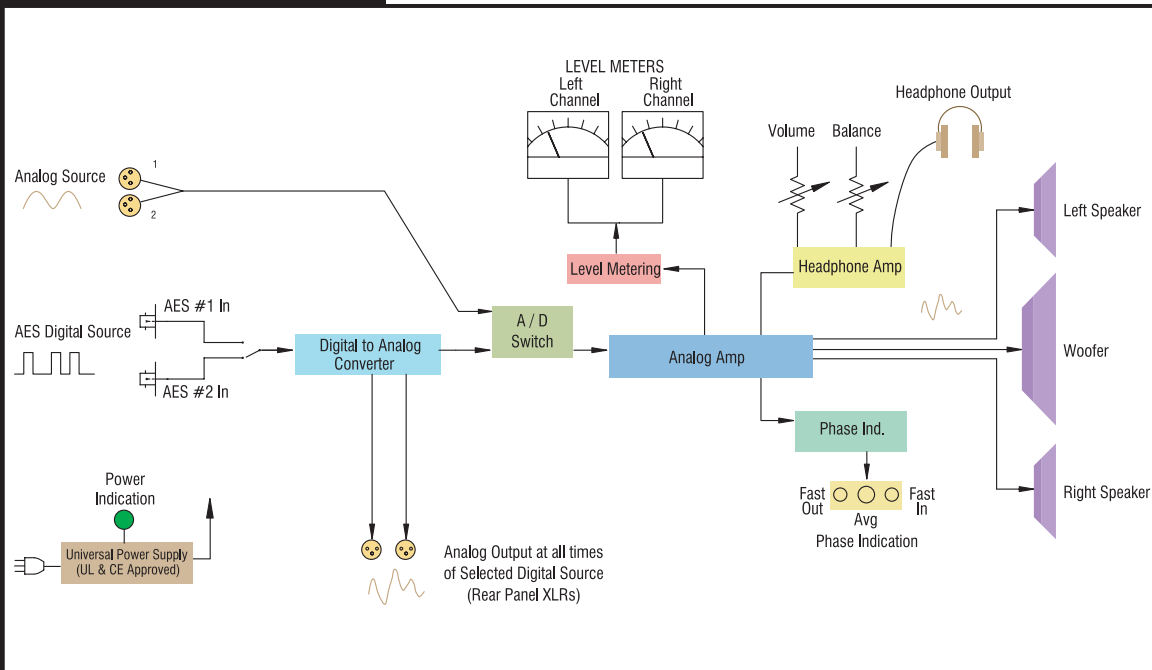

Specifications:

Analog input	2 balanced analog inputs (XLR)
AES/EBU input	2 unbalanced AES/EBU inputs (BNC)
Analog output	balanced analog output of selected digital pair (XLR)
Level meters	2 x mechanical VU meters
Level meter threshold	-6, 0, +4, or +8 dBV: DIP switch selectable
Midscale resolution	1dB
Peak acoustic output @ 2 feet	104dB SPL
Power output	RMS each side (4 Ohms) - 10W, 14W peak RMS center WOOFER (4 Ohms) - 25W, 35W peak
Frequency response (1/6 octave)	80Hz - 16kHz (±5dB) (-10dB @ 40Hz, 22kHz)
Analog input impedance	>40 kOhms balanced
AES/EBU input termination	75 Ohms unbalanced
AES/EBU input sampling rate	32-48kHz, auto-detecting
Hum and noise	better than -68dB below full output
Electrical distortion	<0.15% at any level below limit threshold
Acoustic distortion	.6% or less worst case frequencies above 120Hz including cabinet resonance, typically < 1.5%
Magnetic shielding	<0.8 gauss any adjacent surface
Power consumption (AVG. MAX.)	.45W
Dimensions (HxWxD)	3.5 x 19 x 12" (44.5 x 483 x 305mm)
Weight (approx.)	18lbs (8.2kg)
Power supply	100 to 240VAC, 50/60Hz universal input CE and UL approved

All specifications are subject to improvement



Toll Free (US): 1.888.5.WOHLER • Tel: 510. 870.0810 • Fax: 510.870.0811
31055 Huntwood Avenue, Hayward, California 94544, USA
www.wohler.com • sales@wohler.com