

World Leader • In-Rack • Audio & Video Monitoring

WOHLER LM26-24D

AES/EBU Digital 24 Channel In-Rack Professional Level Metering System



February 10, 2004

Features:

- AES/EBU Digital 24 Channel In-Rack Professional Level Metering System
- Only 1U of Rack Space
- 24 High Resolution 26 Segment Tri-Color LED Bargraphs
- Simultaneous VU (bar) and PPM (dot) Bargraph Display Ballistics
- Simultaneous Visual Monitoring of all Channels
- 12 Phoenix Input Connectors as Standard, BNC Connectors also Available

Industry Leading Wide Dynamic Range
Accuracy 0.05dB (at 1kHz)

Custom Variations of Standard Scales
and/or Color Masks Available on Request

Adjustable Bargraph Brightness
via Front Panel Control

Power Indicator LED

Quick and Simple Installation

CE and UL approved 100 to 240VAC,
50/60Hz Universal Power Input

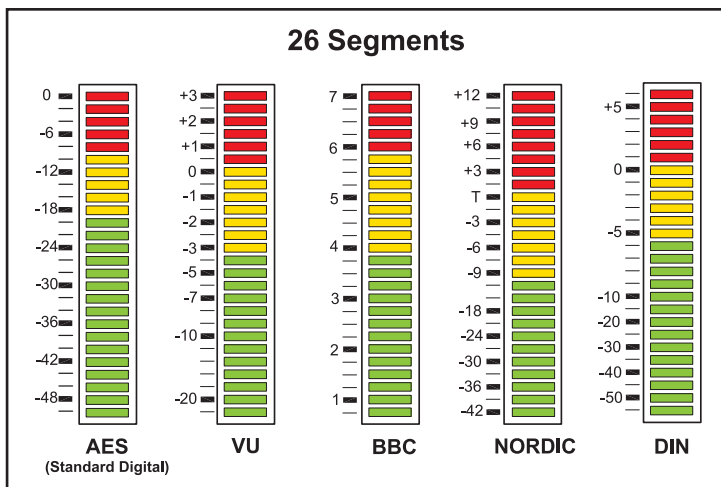

Our LM Series of Analog, EBU digital, SDI and Dolby Digital audio level meters are now available with a choice of BBC, DIN, Nordic and VU scales and "PPM Only" has also been added to the user selectable options. These changes were requested by our customers, if you don't see what you are looking for please do contact us and we'll be glad to help.

Woehler professional level meters are available with 26, 53 or 106 segment bargraphs, providing very high resolution and a wide (>70dB usable) dynamic range in increments as small as 1/2 dB across mid-scale. We also produce level meters containing large segment LEDs with 30 and 60 segments, optimized for viewing from a distance. Versions are available for Analog, AES/EBU Digital, SDI and Dolby Digital sources, providing from 2 to 32 channels simultaneously depending on the model, and are available as 1U or 2U in-rack units. New versions are available requiring only one half-rack space.

Our unique tri-color LED design means we can offer an almost unlimited variety of options such as Phase Correlation, Peak Hold, Loudness, Sum & Difference, and alternate scales & color mappings.

The standard display mode is set as a single segment PPM "dot" above a VU bar; each segment's color is fixed according to its position on the scale.

Level calibration for analog input versions and scale color transition points ("color mask") for digital input versions may be set via dip switches to select one of four different calibration levels (for analog input types) or color mask (for digital input types) via DIP switch settings.

Ideally suited for use in VTR bays, mobile production vehicles, teleconferencing installations, multimedia systems, satellite link and cable TV facilities and on-air radio studios, built and rigorously tested in the USA, the Woehler LM series of professional level meters are backed by a strong warranty and a "Satisfaction Guaranteed" return policy.



Level Metering

Audio Monitoring

Alarm Systems

Video Monitoring

Toll Free (US): 1-888-5-WOHLER Tel: (650) 589-5676 Fax: (650) 589-1355 • 713 Grandview Drive, South San Francisco, California 94080, USA

www.wohler.com sales@wohler.com

WOHLER LM26-24D

AES/EBU Digital 24 Channel In-Rack Professional Level Metering System

Rear Panel:

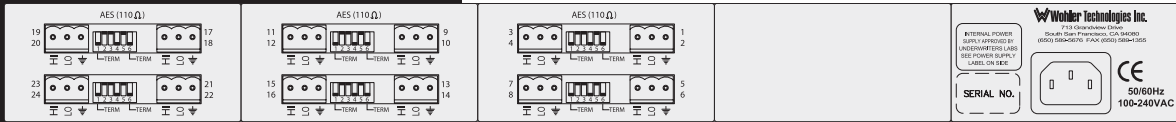

System Diagram:

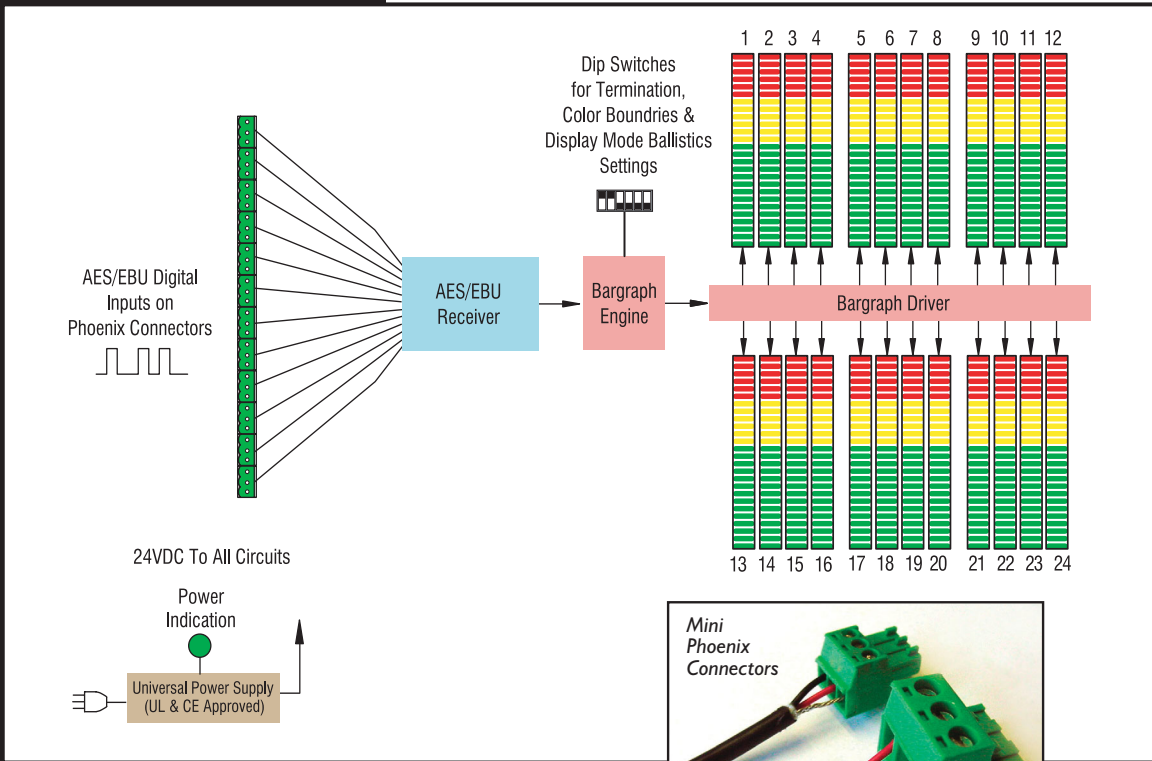

Specifications:

Input connectors	Phoenix
Audio source type	AES/EBU or PCM
AES/EBU input sampling rate	.32 to 48 kHz, auto detecting
Frequency response	10 Hz to 20 kHz \pm 0.05 dB
Input termination settings	110 ohms
Level meters	twenty-four 26 segment high resolution LED bargraphs
Standard scale	-50 to 0 dB
Midscale resolution	.2 dB (Extended VU Scale)
Standard display ballistics	simultaneous VU & PPM (dot over bar)
Selectable display controls	color boundary: -18 dBfs or -20 dBfs floating segment: PPM 3s hold, PPM peak no hold, VU peak 3s hold, VU peak 10s hold
Additional options	alternate scales, color mappings and features such as phase correlation or sum & difference may be specified at the time of ordering, contact us for details
Chassis dimensions (HxWxD)*	1.75" x 19" x 7.5" (44mm x 483mm x 190.5mm) *not including rear panel input connectors
Weight	4.1 lbs. (1.85 kg)
Power consumption	.15W (maximum)
Power supply	100 to 240VAC, 50/60Hz universal input, CE & UL approved

E. & O.E., All specifications are subject to improvement

Visit <http://www.wohler.com/meters.html> for animated metering demonstrations



Toll Free (US): 1-888-5-WOHLER Tel: (650) 589-5676 Fax: (650) 589-1355
713 Grandview Drive, South San Francisco, California 94080, USA
www.wohler.com • sales@wohler.com